

# CALORIQUE WARM FLOORS

*under floor heating panel system*

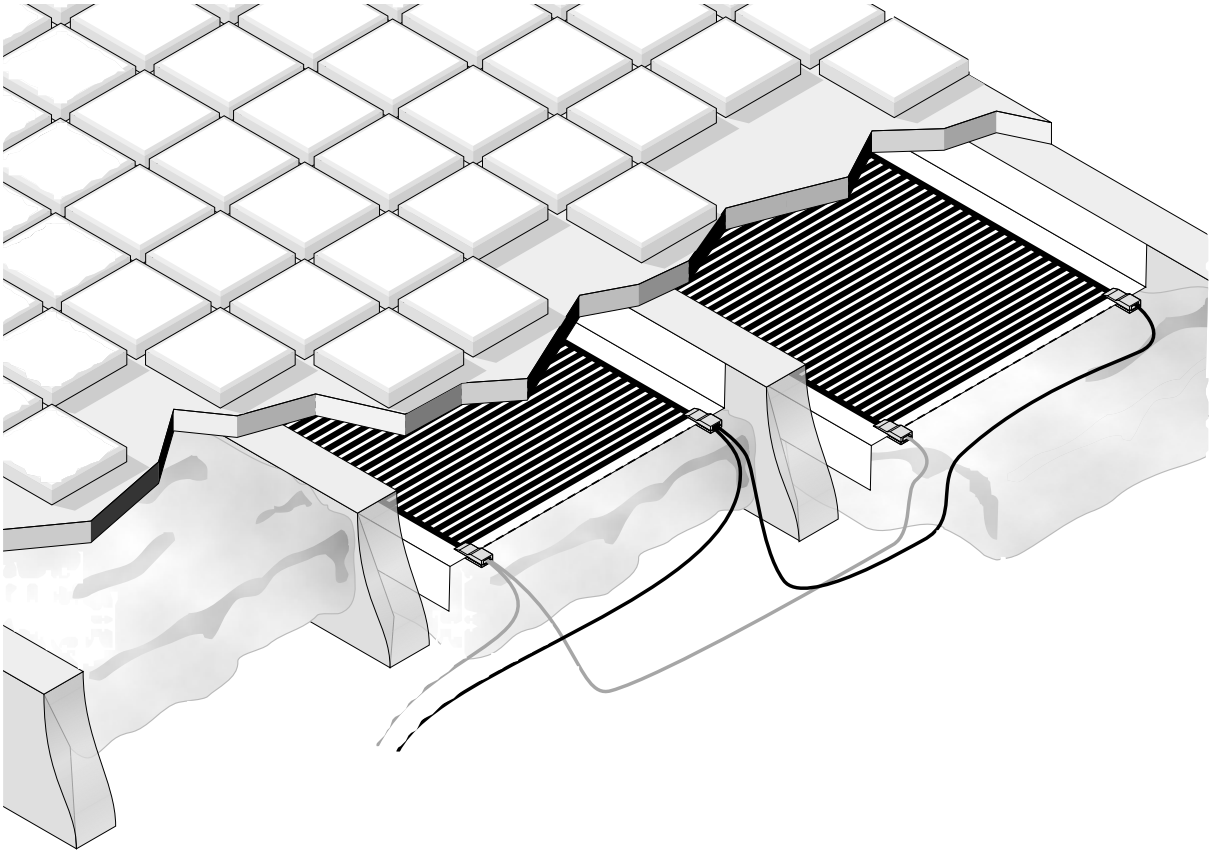

## Installation Manual



THE INSTALLATION OF THIS HEATING PRODUCT SHALL BE IN ACCORDANCE WITH THE MANUFACTURER'S INSTRUCTIONS AND THE REGULATIONS OF THE AUTHORITY HAVING JURISDICTION.



The installation of this heating product shall be in accordance with Article 424, Part J, of the National Electrical Code, ANSI/NFPA 70.



THIS EQUIPMENT SHALL BE INSTALLED ONLY BY QUALIFIED PERSONNEL WHO ARE FAMILIAR WITH THE CONSTRUCTION AND OPERATION OF THE APPARATUS AND THE RISKS INVOLVED.



Heating elements should not be installed at or below 32°F (0°C).

## INTRODUCTION

Calorique's Warm Floors System is a unique heating system that is installed under the floor, between the joists, to provide either primary or supplementary heat. Completely unseen, the Warm Floors heating panel sets warm floor surfaces to about 85°F / 30°C for unparalleled comfort.

Design, installation and use are straight-forward: start by designing the system, then cut the heating panel sets to length, staple them into position between the joists and complete the electrical connections.

There are four sections of this manual:

**Part 1 - Design Criteria** is to be used by the heating system designer. This portion of the manual will generally be followed prior to ordering material. The designs and drawings completed during this stage must be made available to the installer(s).

**Parts 2 - Job-Site Preparation, 3 - Installation and 4 - Inspection • Testing • Completion** will be used by the actual heating system installers. *Job-Site Preparation* provides a complete list of the materials and supplies that must be on hand during the installation and testing of the system. *Installation and Inspection • Testing • Completion* detail the actual installation and testing of the system.

Throughout this manual four types of notes will direct your attention to important information that must be taken into account during the planning and installation of the Calorique Warm Floors System.



This symbol indicates that a fire hazard may exist if a particular action is not followed.



This symbol indicates that a shock hazard may exist if a particular action is not followed.



General notes direct you to pay special attention to these items.

### NOTE

Notes provide short tips for making the installation easier or convey information that falls outside of the direct text of the manual.

The Calorique Warm Floors System is made up of 4 major components: the heating panels, the wiring, the control device and the building structure. These components work together to create a system that will provide comfortable, trouble-free heat. The selection and installation of each component is very important to the system's overall safe operation.

Designing a Calorique Warm Floors System is straightforward — the following instructions must be complied with to ensure a trouble-free design and to comply with the warranty requirements.

## NOTE

A Planning Guide is available to assist in determining the type and quantity of components that are required.

## HEAT LOSS CALCULATION

If the Warm Floors System is to be used as a primary heating system for a room, a heat loss calculation *must* be completed to determine the energy required to adequately heat the space under foreseeable circumstances. The Air Conditioning Contractors of America (ACCA) Manual J includes worksheets for manually calculating the heat loss of a structure. Other, comparable, heat loss methods and/or documents may be used. Make sure that all sources of heat loss (transmission, infiltration and radiant) are taken into account.

Most bathrooms and some kitchens have small available floor areas relative to the volumes of the rooms, the maximum possible amount of installed heat is often insufficient to supply the demand. Bathrooms and other areas where there is not enough available floor space to allow installation of sufficient Calorique heating panels to act as a sole source of primary heat must use a supplementary or alternative heat source, such as high power radiant panels, baseboard heaters, etc.

## NOTE

Some heat loss methods, particularly those designed for gas and oil based systems, provide their answers in Btus per hour. To convert Btus per hour to watts, multiply each area total by 0.293 (or divide by 3.41).

## NOTE

Always include a recovery factor of at least 20% more than the minimum calculated heat requirement to cover unforeseen circumstances.

## NOTE

ACCA may be contacted at 202-483-9370, 1712 New Hampshire Ave. NW, Washington DC 20009.



A separate heat loss calculation must be done for each enclosed area (room, etc.). A separate control device must be included for each enclosed area.



Do not install Calorique as a primary heating system in any bathroom, room or other area which does not have at least as much heat installed as is called for by the heat loss calculation, plus the recovery factor.



All wiring, fuses and/or circuit breakers must conform to National Electrical Code.

#### NOTE

A thermostat or appropriate control must be provided for each room in which Warm Floors is being used as a primary heat source.

The fuse or circuit breaker used must be rated for a maximum of 20 amperes (no greater than 16 amp load). If a lower rated fuse or circuit breaker is used, it must be rated at least 25% greater than the heating system load attached to it. If an area requires more than the 16 amperes allowed, additional branch circuits may be used, each having its own overcurrent protection. These branch circuits may all be controlled by a single thermostat if it is used with a system of electric relays.

#### NOTE

The National Electrical Code specifies that each branch circuit used in conjunction with a heating system must be for the exclusive use of the heating system. Do not connect lights, outlets, etc. to any branch circuit used with the Calorique Warm Floors System.

The selection of a control device will be determined by the designed use of the system. If installed and used as a primary heating system, a thermostat must be used. If designed to be used as a supplemental or floor warming system, timers or other control devices also may be used. The Calorique Warm Floors System can be controlled by any standard line voltage method — including line voltage thermostats or low voltage thermostats in conjunction with line voltage relays. Whichever control option is used, all components must meet all applicable local and national codes and be rated for use with an electrical heating system.

## FLOOR CONSTRUCTION

**Joists** — The Calorique Warm Floors System is designed for use with typical wood and/or metal floor joists. The joists must have a facing width no greater than 2 inches / 50 mm with a spacing between the joists strips of 12, 16 or 24 inches on center / 300, 400 or 600 mm.

**Floor Surface** — The floor surface may be of any material having a total thermal insulation value of less than R-11 / RSI-2 — this includes any floor finish such as tile, hardwood, carpet, as well as secondary materials added to the floor at a later time. Contact the material manufacturer for specific information concerning the thermal insulation factor of the material being specified.

**Surface Finish** — Any type of surface finish can be applied to the finished floor — the total thermal insulation value of the sub-floor and floor finish must not exceed R-11.

#### NOTE

Do not use the Warm Floors System to cure adhesives, stains or paints since direct heat during curing may cause cracks or discoloration.



Metal joists must be properly grounded in accordance with local codes.

**Insulation** — The only types of insulation permitted with the Calorique Warm Floors System are:

- Unfaced fiberglass batt insulation
- Rigid insulation panels

#### NOTE

When the Warm Floors System is used as a primary heating system, all walls, ceilings and floors that separate a heated space from an unheated space or the out-of-doors must be insulated to ensure proper operation of the system.

### DESIGN CLEARANCES

When designing the heating system, care must be taken to ensure that proper clearance is maintained from electrical fixtures, cabinetry, partition walls and other permanent features.

**Permanent Features** — Calorique heating panels must be installed so that they will not be covered, even in part, by partition walls or other structures that cross the floor. Heating panels which are covered by any structures may overheat.

**Wiring** — Electrical wiring, in the floor must be at least 2 inches / 50 mm away from the heating panels with a barrier of insulation filling that space. This space may be horizontally along the joist space.

**Surface Mounted Fixtures** — Do not install Calorique heating panels closer than 8 inches / 200 mm from the edges of any electrical boxes for surface mounted fixtures in the floor since surface mounted fixtures may have additional trim which extend far beyond the edges of the electrical boxes.

**Recessed Fixtures** — At least 2 inches / 50 mm of clearance must be maintained between the trim of recessed fixtures or outlets and the Calorique heating panels.

**Heat Sources** — At least 8 inches / 200 mm of clearance must be maintained between heat sources and the Calorique heating panels. This includes hot water pipes. If not possible, use pipe wrap on pipes.

**Pipes** — At least 2 inches / 50 mm of clearance must be maintained between any pipes (metal or plastic) and the Calorique heating panels. This includes hot water pipes. If not possible, use pipe wrap on pipes.

**End of Joist Cavities** — Leave at least 6 inches / 150 mm of clearance at each end of each joist cavity to accommodate wiring and assembly.



Use only non-combustible insulation.



Do not use cellulose insulation of any kind.



Do not use metal foil faced insulation or metallic vapor barriers.



If a vapor barrier is required, install it normally to the upper sides of the joists. This installation may be done before or after the heating panels have been attached or wired, depending on access.

A typical Calorique heating panel set.

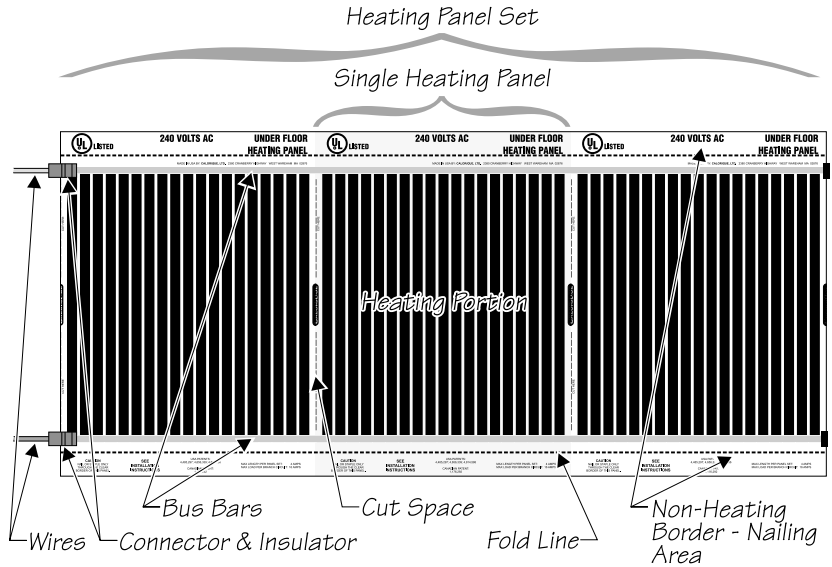

Calorique’s Warm Floors System is available in three standard widths and two standard voltages. Match the joist spacing and voltage available to the appropriate heating panel(s) in the following table:

Joist Spacing	Watts / Panel	120 Volts AC	240 Volts AC
12 inch / 300 mm	8	FLR13P8W120V	FLR13P8W240V
max. length:		45 panels	90 panels
16 inch / 400 mm	10	FLR17P10W120V	FLR17P10W240V
max. length:		36 panels	72 panels
24 inch / 600 mm	17	FLR25P17W120V	FLR25P17W240V
max. length:		21 panels	42 panels

**NOTE**

If a particular room or area includes more than one joist spacing (e.g. some joists spaced at 12 inches and some spaced at 16 inches), you must use the appropriate heating panel for each joist spacing.

The maximum length for a particular model means the maximum continuous length of heating panels for any one run, or panel set. This length is governed by the maximum amperage that the bus bars are designed to carry.

The total number of panels used in a single circuit is limited to 16 amps. Use the following table as a quick reference when specifying only single voltage/width heating panels. When specifying multiple width heating panels for the same area, make sure that the total power (watts / panel times the number of sections for all product types) is less than or equal to the maximum total power figure.

Voltage	Maximum Total Power	Maximum Total Panels		
		12 inch	16 inch	24 inch
120	1920 watts	240	192	112
240	3840 watts	480	349	225

## PREPARATION

Before work can proceed, all plumbing and electrical wiring that will not be accessible after installation of the heating system must be completed. This may require coordinating with the electrical and/or plumbing contractor(s).

Make sure that insulation has been installed in areas that will be inaccessible after installation of the heating system. This may require coordinating with the insulation contractor.

Before installing the Calorique Warm Floors System, all of the following must be available at the job-site.

### NOTE

Those components marked with the • symbol are supplied by your Calorique distributor.

## COMPONENTS

Name	Part Number	Description
•Heating Panels	table pg 4	The number and type of heating panels needed must have been calculated before-hand as outlined in Part 1-Design Criteria. Enough panels must be on hand to account for any errors in cutting, job-site damage, etc.
•Electrical Connector	FC-1001	Solderless Tyco/AMP Termi-foil electrical crimp connector.
•Electrical Insulator Thermostat or Control	FB-1001	Clear plastic snap-type insulator. UL Listed thermostat or other appropriate control rated for at least 25% greater capacity than the installed heating load. Low voltage units may be used in combination with appropriate relay.
Thermal Insulation		The insulation must be of the non-flammable type specified during calculations done per Part 1. See page 3 for details.
Non-Heating Leads		Branch circuit supply conductors shall be no larger than #12 AWG or smaller than #14 AWG, with overcurrent protection of 20 amperes. Type UF single conductor or equivalent.



Make sure that the job-site is neat and clean before working with the Calorique radiant heating panel sets. Nails, screws and other sharp debris can damage the panels. Any panels which become torn or otherwise damaged must be discarded.



If insulation is being installed by another contractor, this information must be made available and compliance ensured.



Type NM and NMC non-metallic sheathed cable is not suitable for installing this product.



Caution: Use copper only as supply conductor.

**COMPONENTS** - continued

•System Warning	CW1007
Labels	CW1009
	CW1011

These labels are an integral part of this heating system and must be installed for the warranty to be in force. See page 14 for details on affixing these labels. One of each type label is provided for each 16 meters of heating panels (50 panels).

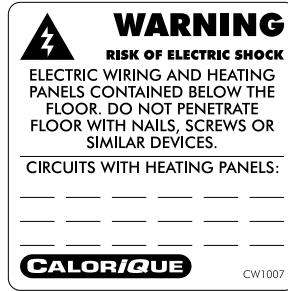

Dielectric Tape

UL listed and/or CSA certified "electrical" tape rated for at least 90°C / 194°F.

Ohm-Meter or Multi-Meter

An accurate ohm-meter or multi-meter must be used during the testing phase to ensure that the system is correctly installed. It is suggested that a digital meter is used rather than an analog (needle) type.

•Instruction Manual CM1004

This document.

•Check List & Information Card CL2002

The installation check list and information card must be returned to Calorique. Calorique will send a warranty registration card.

•Operating Manual CM1002

The operating manual lists detailed information about the heating system. This manual must remain with the home or building owner when the job is done.



Name	Part Number	Description
•Combination Crimping Tool	FCT-104	Used to attach electrical connectors to the heating panels and wires to the connectors. Manufactured by Harbin Sanzing Calorique Heating Company, Ltd.
Staple Gun		Standard automatic stapler. Used to attach Calorique panels to ceiling joists. Recommended staple length: 5/16 or 3/8 inch / 8 or 9.5 mm.
Assorted Hand Tools		Conventional electrical wiring hand tools.
Knife and/or Scissors		Used to cut heating panel sets from the supply roll.



Use only those crimping tools specifically provided by Calorique.



Nominal spacing when the crimping tool is fully closed is 0.095 inch (2.4 mm).

## **PART 3 - INSTALLATION**

### **INSTALL CONTROL DEVICE BOX**

Install a junction box for the control device. If this device is a thermostat, the box should be located, unobstructed, on an inside wall so that the device reads accurately.

### **PREPARE THE HEATING PANELS**

Prepare all heating panels for each room at one time prior to starting installation.

1. Cut the panel(s) to length.  
Using a knife or scissors, cut panel sets according the layout made in Part 1.
2. Attach connectors to one end of each heating panel set.  
Center a connector over one end of each bus bar, pressing them in place with finger pressure and then crimp each connector in place using the flat portion of the crimping tool as shown in the following figure.



Calorique radiant heating panels must be installed as outlined in these instructions.



Cut heating panels only along the dashed "cut here" lines.

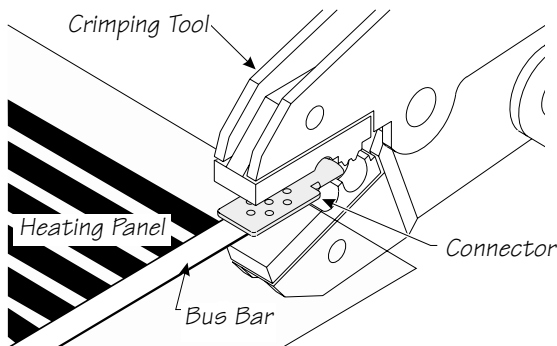



Do not pierce the panels within 3/8 inch / 10 mm of the bus bar or heating portion of the panel.



The heating panels must run smooth and flat between the joists. There must be no wrinkles in the heating panels.



Heating panels must run parallel to the joists they are attached to.

3. Insulate the other end of each bus bar.

Place a length of electrical tape over the exposed end of each bus bar opposite the electrical connector.

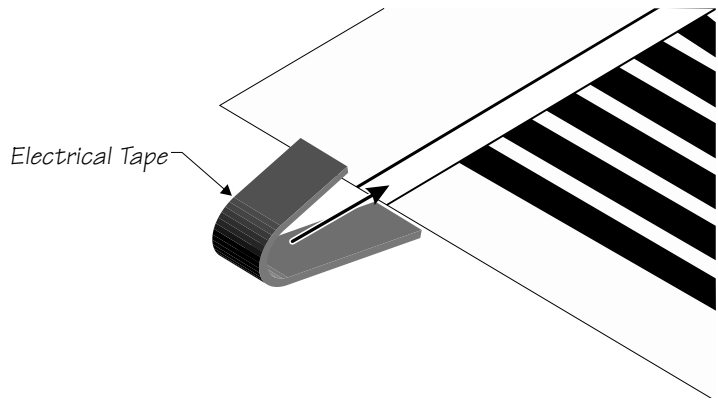

### ATTACH HEATING PANEL SETS

1. Align a heating panel set with one of the joists to which it will be attached. Make reference to the layout made in Part 1 for heating panel locations.
2. Nail or staple the panel set in place, leaving at least 6 inches / 150 mm clearance to walls or partitions at the connector end for wiring and final assembly. Nail or staple as close to the perforated bending line as possible, maintaining a 2 inch (50 mm) space between the perforation and the top edge of the joist. Nails or staples must be placed at least once every 12 inches / 300 mm along each side of the heating panel set.

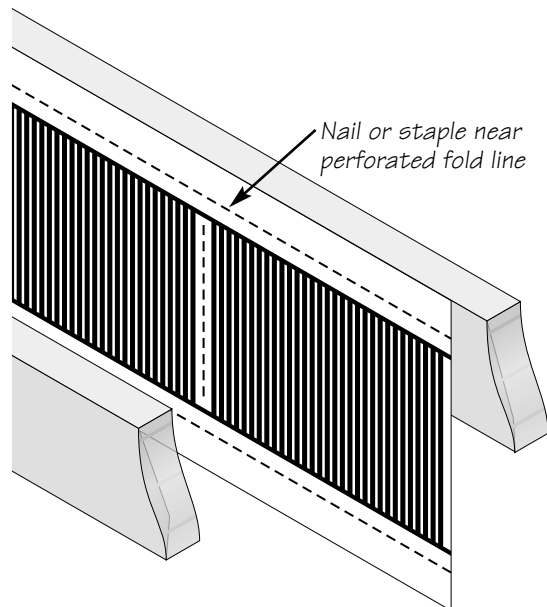

**NOTE**

Aligning heating elements to provide a 2 inch / 50 mm air gap above the heating panels. This air gap is required for the proper operation of the Warm Floors System.

3. Fold the heating panel so that it runs level between the two joists and nail or staple the other side into position.

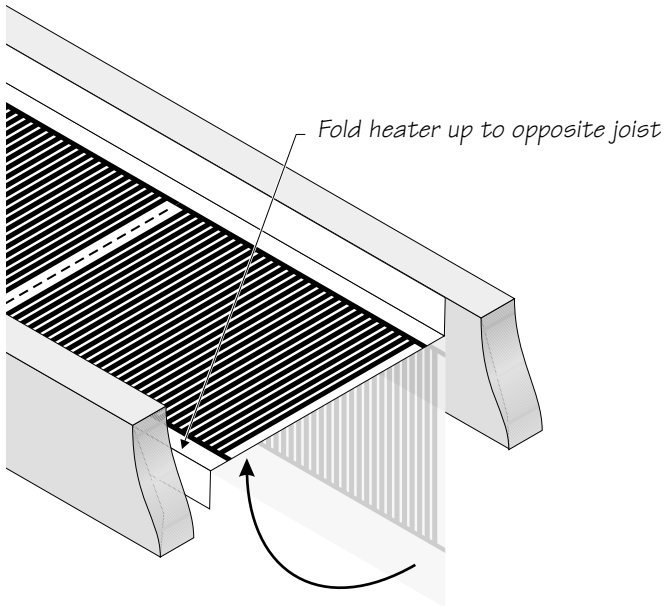

4. Repeat for each heating panel set, then continue to the next section, Wire the Heating Panel Sets.

## Floor Heating Panels and Ceiling Heating Panels Installed in the Same Joist Space



See the Calorique Ceiling Heating System installation manual for complete details on the installation and testing of that system.



Use at least 3 inches / 75 mm of unfaced fiberglass insulation to insulate between the heating panel sets of the two systems. If joists are greater than 6 inches / 150 mm in depth thicker insulation must be used to avoid air pockets above the ceiling heating panel sets.

### NOTE

INTENDED FOR INSTALLATION IN A COMMON JOIST SPACE WITH COMPLEMENTARY CEILING HEATING PRODUCT RATED 17 WATTS PER SQUARE FOOT MAXIMUM. See the Complementary Heating Products table below for a list of heating elements that may be used in the same joist space.

- If access is from above, completely install the radiant ceiling heating system (including wiring and testing), insulate above the panel sets and then completely install the floor heating system.

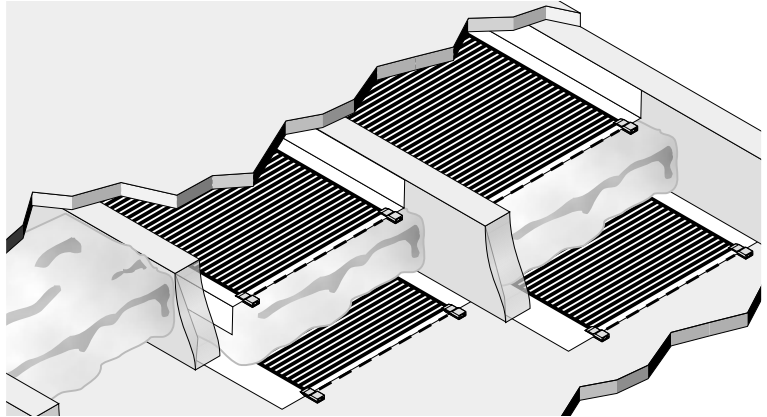

- If access is from below, completely install the floor heating system (including wiring and testing), insulate below the heaters and then completely install the ceiling heating system.
- Repeat for each heating panel set, then continue to the next section, Wire the Heating Panel Sets.

### Complementary Heating Products

<b>Ceiling Heating Products</b> ►	<b>RCH13P13W240V</b>	<b>RCH17P17W240V</b>	<b>RCH25P25W240V</b>
<b>Floor Warming Products</b> ▼	17 W/SF	17 W/SF	17W/SF
<b>FLR13P8W120V</b>	10 W/SF	complementary	complementary
<b>FLR13P8W240V</b>	10 W/SF	complementary	complementary
<b>FLR17P10W120V</b>	10 W/SF	complementary	complementary
<b>FLR17P10W240V</b>	10 W/SF	complementary	complementary
<b>FLR25P17W120V</b>	10 W/SF	complementary	complementary
<b>FLR25P17W240V</b>	10 W/SF	complementary	complementary

## WIRE THE HEATING PANEL SETS

Wire the heating panels in parallel according to the following figures. Repeat the steps for each electrical connector.

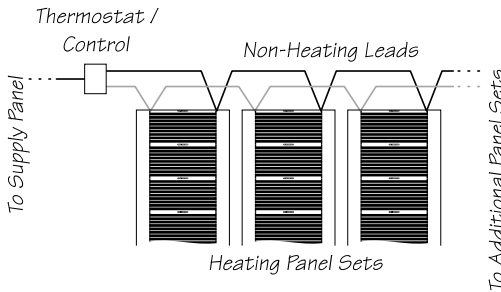
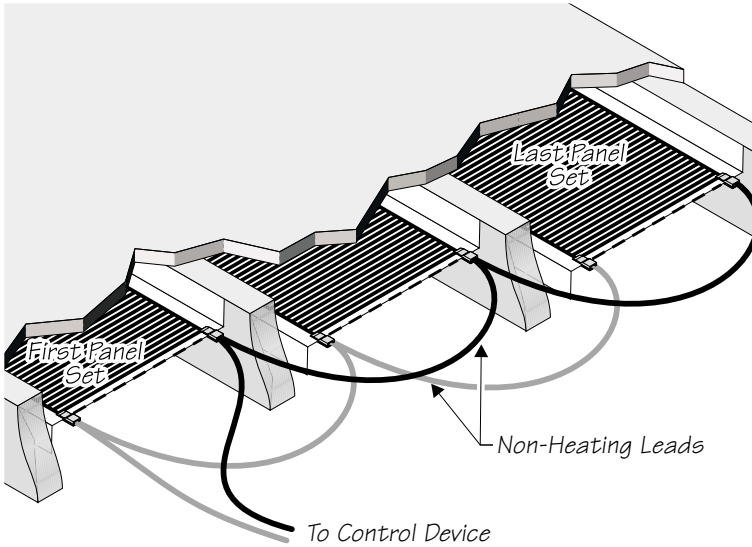

1. Strip the non-heating lead wire(s) that will be attached to the connector. Strip about 1/4 inch / 6 mm.
2. Insert the wire(s) into the barrel section of the connector.
3. Crimp the wires in place using the barrel crimping section of the crimping tool as shown in the following figure.

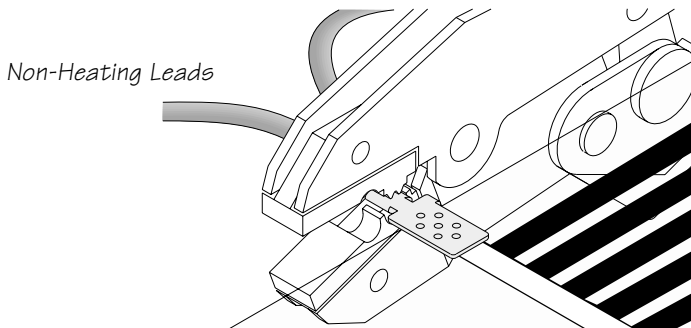

Route and secure wires between the heating panels, from the heating panels to the thermostat box and from the thermostat box to the electrical panel using standard wiring practices that conform to all of the requirements of all applicable electrical and building codes.



**WARNING-  
RISK OF  
ELECTRIC**

**SHOCK AND FIRE  
DAMAGE TO THE  
SUPPLY CONDUCTOR  
INSULATION  
MAY OCCUR IF  
CONDUCTORS ARE  
ROUTED LESS  
THAN 2 INCHES  
(51 MM) FROM  
THIS HEATING  
PRODUCT. REFER  
TO INSTALLATION  
INSTRUCTIONS  
FOR RECOMMENDED  
MEANS  
OF ROUTING SUPPLY  
CONDUCTORS.**

4. Insulate the connector by snapping an insulator in place over it.

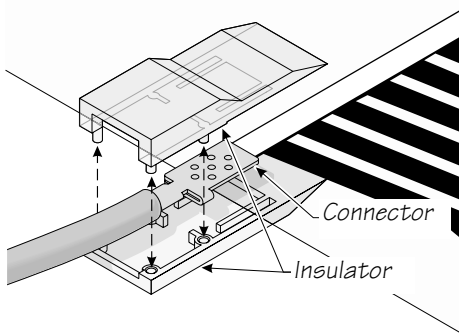

5. Repeat for all of the heating panel sets.

## PART 4 - INSPECTION / TESTING / COMPLETION

A visual and electrical check must be performed on the heating panels prior to activation.

### VISUAL INSPECTION

When visually checking the panels, look for any signs of damage, wear or scratching that might have occurred during installation. If any portions of a panel set appear damaged, replace the entire panel set.

### ELECTRICAL TEST

A resistance check across the supply leads using an accurate ohm meter must be made to detect any short or open circuits — record the resistance readings. If only one type of panel has been used within an area, use the resistance chart in the operating manual to determine the acceptable readings. If more than one type of panel has been used in the area, use the following formulae to determine the acceptable resistance values:

	<b>120 Volt Panels</b>	<b>240 Volt Panels</b>
high resistance limit =	$\frac{15,840}{\text{installed watts}}$	$\frac{63,360}{\text{installed watts}}$
low resistance limit =	$\frac{13,680}{\text{installed watts}}$	$\frac{54,720}{\text{installed watts}}$

To determine the total installed watts, multiply the number of individual heating panels by the wattage per panel for each type of panel.



If any connectors must be replaced, ensure that the heating panel has not been damaged by removing the original connector. If it has, then the entire panel set must be replaced.



Any connectors which are removed must be replaced. A connector may only be crimped once.

Reading	Indication	Action
Between high & low resistance limits	Good	System is connected properly. No action is necessary.
Higher than high resistance limit	Open Circuit	Check all electrical connectors and rewire or replace any that are attached improperly.
Zero (0)	Short Circuit	Check the path that the wiring is taking and make sure that no wires are attached to both bus bars of a single panel. If any are, remove the wires

After any remedies have been performed for open or short circuits, if any, retest the system.

## COMPLETE THE INSTALLATION

1. Install control device and connect to electrical panel box.  
Install and wire the control device according to manufacturer's instructions in the junction box added at the beginning of Part 3 — Installation.
2. Install thermal insulation.  
The insulation may be installed in the normal manner.

### NOTE

Tuck insulation up at the end of each panel set so that it seals in the heating panel set. This will help keep heat from escaping and improve the efficiency of the system.

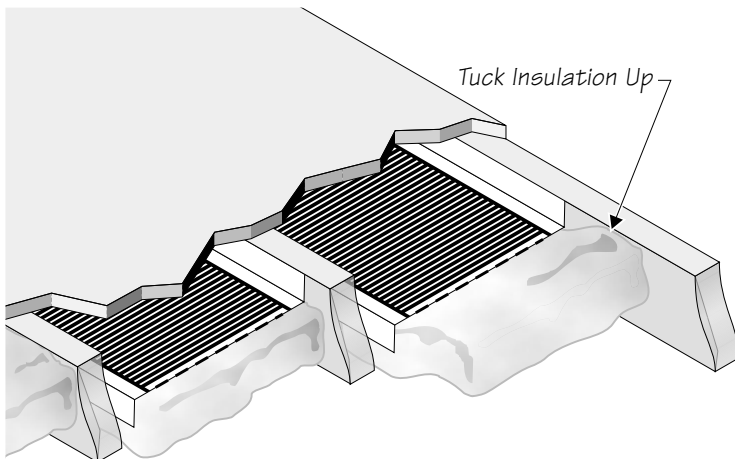

3. Finish the floor in any normal fashion.
4. Install a floor covering in accordance with the designer's notes.



See page 3 for more information about thermal insulation.



Any material used as a floor surface must be appropriate as noted on page 2.



Follow the guidelines on page 2 for floor finishes.



The system labels are an integral part of the heating system and must be attached as noted here. Failure to attach system labels is in violation of the warranty and may result in revocation of the warranty.

5. Attach system labels in the locations noted below:

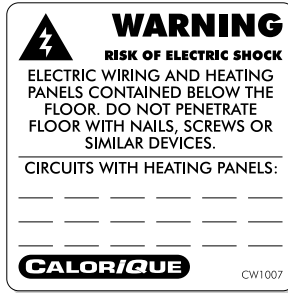

**CW1007:** Affix to the electrical panel box. In the space provided, record the numbers of all circuits to which floor heating panels are attached.



**CW1009:** Affix adjacent to points of access to all concealed areas in which installed heating products are accessible.



**CW1011:** Affix to all devices controlling radiant heat (thermostat, switch, etc.).



The warranty on the system is activated when Calorique returns a warranty card. The warranty card is mailed to the address of the installation only after the system registration card is received by Calorique. Calorique is not responsible for lost or misdirected mail.

## DOCUMENTATION

The Check List & System Registration Card records vital information about the installation you have just made — fill out all requested information. The bottom copy is returned to Calorique to register the installation, the other two copies are for the home owner and the installing contractor respectively.

The Operating Manual lists detailed information about the heating system. The manual must be attached to the service panel so that it is easily accessible to the homeowner and any repair and/or remodeling technicians.

